



Beede Electrical Instrument Company, Inc.
 88 Village Street, Penacook, NH 03303-8910
 Phone: (603) 753-6362 FAX: (603) 753-6201

Since 1917 Visit our WEB site <http://www.beede.com> ISO 9001 CERTIFIED

- AGRICULTURAL
- AUTOMOTIVE
- INDUSTRIAL
- MARINE
- TRUCK
- BUS

WARRANTY

Beede Electrical Instrument Co., Inc. warrants all instruments and accessories free from all defects in workmanship and materials on gauges that are less than three (3) years old or have been in service fewer than two (2) years and, at no charge, will replace or repair at Beede's option all instruments that fail. Contact Beede for complete details.

2" Four Function Warning Instrument W/Connector

⚠ WARNING

Improper installation may damage the instrument and/or cause injury to the installer. If you have installation questions, please contact the factory.

Disconnect battery cables before installing the instrument.

Check for obstructions behind dash panel such as wires and hoses before cutting the mounting hole for the instrument.

MOUNTING

Recommended dash hole size: 2.125±.015 in (53.98±0.38 mm) DIA.

Secure the instrument into dashboard with mounting "J" clamps and Kep nuts.

If dashboard thickness exceeds clamp grip range, clamp legs may be shortened.

Position instrument in dash board prior to tightening clamp nuts to recommended torque.

Maximum recommended tightening torque for all hardware: 6 lb-in (0.68 N-m).

Caution, over tightening mounting hardware may damage the instrument.

MAINTENANCE

Periodically check and torque all hardware per mounting specifications.

Clean glass with a soft, damp, clean cloth.

THANK YOU!

Thank you for purchasing a Beede instrument. Our instruments are made for you in the U.S.A. Visit our WEB site at www.beede.com or contact customer service for information on this or other Beede instruments.

Gauge Wiring Table	
Gauge Pin Number	Connection
1	Battery +
2	Lower Left Jewel
3	Upper Left Jewel
4	Lamp Test (If Applicable)
5	Upper Right Jewel
6	Lower Right Jewel

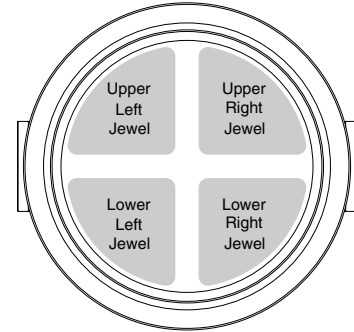
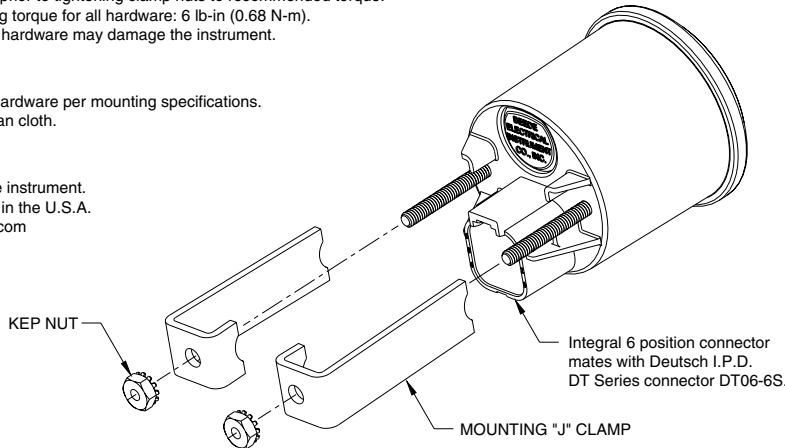

FRONT VIEW OF INSTRUMENT

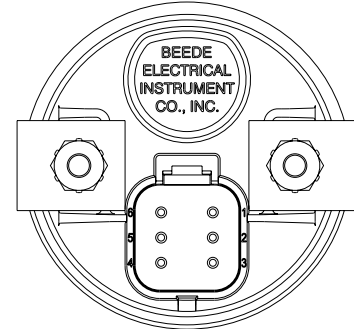

REAR VIEW OF INSTRUMENT